

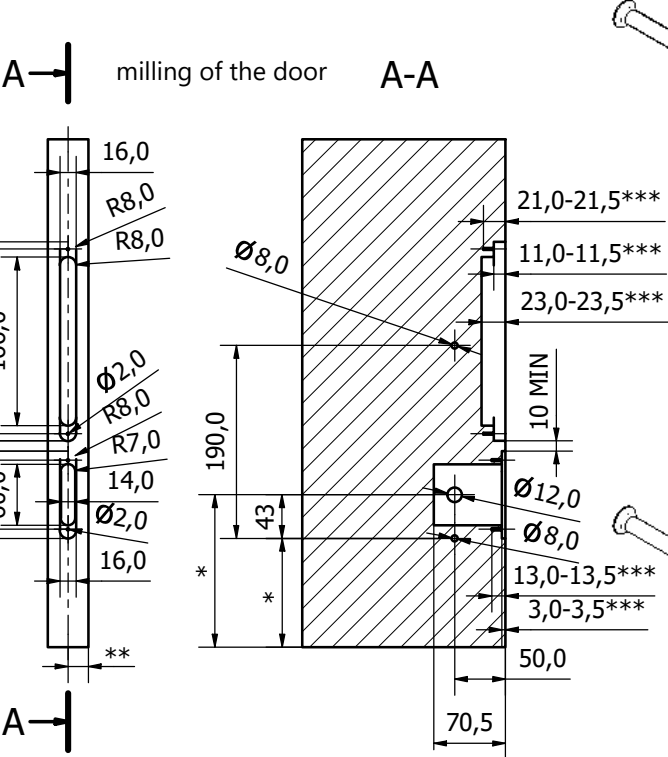

MOUNTING HAND GRIP YES! 210 WC

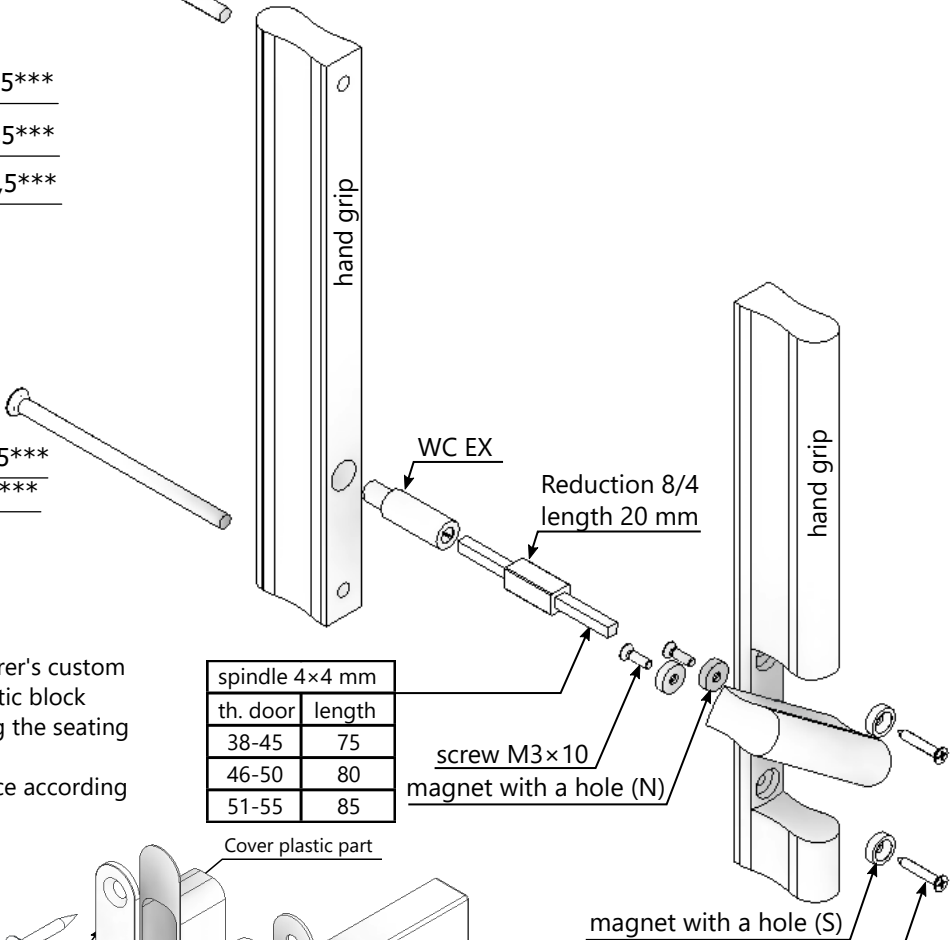

screw M5×90 mm for door thickness 38 - 50 mm
(screw M5×100 mm for door thickness 51 - 60 mm)



* according to the door manufacturer's custom
** fitting / positioning of the Magnetic block in the door must be solved following the seating of the Magnetic in the door frame
*** placing of the magnetic block face according to the door manufacturer's custom

spindle 4×4 mm	
th. door	length
38-45	75
46-50	80
51-55	85

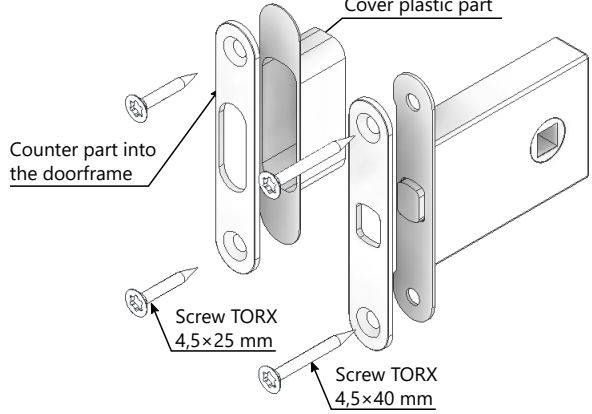
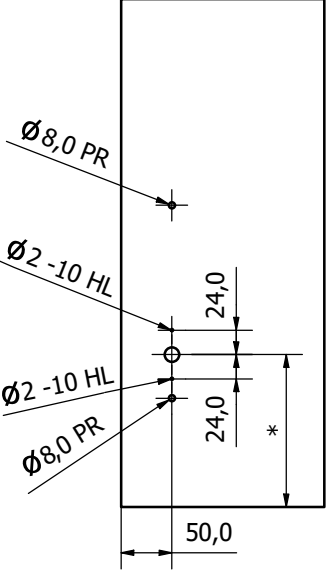

- | component | quantity |
|-------------------------------------|----------|
| hand grip Yes! WC IN | 1 pc |
| hand grip Yes! WC EX | 1 pc |
| WX EX Yes! | 1 pc |
| spindle 4×4 mm | 1 pc |
| reduction 8/4 mm, l. 20 mm | 1 pc |
| magnet with a hole 3×10 (S) | 2 pcs |
| screw M5×90 mm
(screw M5×100 mm) | 2 pcs |
| screw 2,5×16 mm | 2 pcs |
| WC lock WC | 1 pc |
| cover plate of the lock | 1 pc |
| counter plate into doorframe | 1 pc |
| cover part plast | 1 pc |
| screw Torx 4,5×25 mm | 2 pcs |
| screw Torx 4,5×40 mm | 2 pcs |

